



CC Burner Series Instruction Sheet

The CC Burner Series uses propane, natural gas, or hydrogen (CC-H model only) with oxygen and air (with optimizer use) to create a wide range of flame characteristics for flameworking applications. This instruction sheet is designed to provide the user with a working knowledge of the burner to allow for safe and educated use. This instruction sheet is not intended to be a guide for flameworking, but rather a guide for use of the CC Burner family of products. Please take the time to thoroughly read through this instruction sheet to help ensure the proper use and maintenance of the burner. This instruction sheet provides information about the CC, CC+, CC++, CC + RP Model, and accessories.

Options and Accessories:

The CC Burner Family has several options and accessories that are available. This section is intended to provide any pertinent information for the CC options.

- **#3 Centerfire Tip:** The #3 centerfire tip is a smaller orifice than the #5 centerfire tip. It is intended for use with propane and oxygen or when used with natural gas, a smaller, sharper pinpoint flame is achieved. This size difference is often desired when using propane to ensure that the flame remains stable.
- **#5 Centerfire Tip:** The #5 centerfire tip is the standard size that has been offered by Carlisle for many years. This centerfire tip was designed for use with natural gas and oxygen. Although this tip can be used with propane and oxygen, the end of the "candles" and flame may flicker slightly. If this is not desirable, a #3 centerfire tip may be a better choice.
- **RP Model Option:** This is a specially designed model endorsed by the renowned artist Roger Parramore. He wanted a CC+ model with certain features that included a more tapered all stainless steel nozzle shell and rack and pinion mount. Others have obviously appreciated his features.
- **Stainless Steel Head Option:** This option is available on all CC family burners. Replace the brass nozzle with all stainless steel construction.
- **Optimizer Option:** This new option is available on all CC products (except the mini CC). This feature precisely pre-mixes compressed air with the fuel gases of both the center and outerfire to an optimized mix. The result is operational cost reductions with a cooler flame and dramatically increases the flexibility in flame characteristics while keeping the torch cooler. This feature has improved results when working with exotic colors, but require a compressed air source of 125 CFH capacity.
- **CC-H:** This model of CC Burner is intended for use with hydrogen and oxygen and utilizes a non-piloted centerfire tip to provide a sharp, pinpoint, stable flame. When hydrogen gas is utilized, the high speed in which the gas is consumed and the BTU content in which hydrogen gas produces, will prematurely destroy a piloted tip if used.

Carlisle Machine Works, Inc.,
P.O. Box 746, 412 S. Wade Blvd., Bldg. #5, Millville, NJ 08332
Toll Free Phone : (800) 922 - 1167 Local Phone : (800) 825 - 0627
Fax: (856) 825 - 5510
Website: carlislemachine.com Email: carlisle@carlislemachine.com



Options and Accessories cont.:

- **Ball and Post Mount:** The Ball and Post Mount is the standard option available for the CC family of products. This mount uses a post attached to the base with a socket joint. This allows for basic manual articulation of the burner head.
- **Rack and Pinion Mount:** The Rack and Pinion Mount is one of the mounting options available for the CC Burner. This mount uses a straight stand and gear setup to provide a range of motion of the head through the use of knobs. This movement is limited to straight forward angles.
- **CC Water Cooling Options:** Water cooling reduces the burner temperature and increases longevity by retarding heat build-up within the burner. There are two water cooling options. The most economical of these options consist of the removal of the Heat Exchanger, and the addition of a water-cooling jacket constructed of coiled tube, this option is also easy for the consumer to install and remove if necessary. For ultimate cooling choose the integrated machined water chamber option. This replaces the entire shell of the burner and must be installed at the factory at time of purchase, or the burner must be shipped to Carlisle for installation.
- **EL-2 Foot Controller:** The current foot controllers that are available for the CC Burner family are intended to control the outerfire only. (all surface-mixed) This requires that the burner be fitted with four inlets (two gas, and two oxygen), so the foot controller can be separated from the centerfire. The EL-2 is an electronic foot-actuated positive closing valve system.
- **Lathe Mount Attachment Option:** This is a custom slide attachment for mounting a burner on a lathe fire carriage for adjustability.
- **In-Line Disposable Filters Option:** This is a highly recommended option to filter the fuel gas (except hydrogen) and oxygen gases prior to the burner to reduce the possibility of containments from the feed piping and supply sources.
- **Independent Pilot Option:** This option allows the operator to have a standing pilot light as an ignition source at the face of the burner for convenience.
- **Hose Options:** There are three types of hosing recommended for CC Series burners, Welding hose, Tygon hose, and Stainless Steel Braided hose. Please refer to Bulletin 24D for more information regarding these products.

Carlisle Machine Works, Inc.,
P.O. Box 746, 412 S. Wade Blvd., Bldg. #5, Millville, NJ 08332
Toll Free Phone : (800) 922 - 1167 Local Phone : (800) 825 - 0627
Fax: (856) 825 - 5510
Website: carlislemachine.com Email: carlisle@carlislemachine.com



Assembling Burner Head to Base:

In order to protect your CC burner during shipment, the burner head and the base assembly are shipped separate. Before using your CC burner, you must attach the burner head to the base assembly by following the steps below.

CC

1. Turn Burner Head onto post thread at the attachment point using a clockwise motion. Turn until burner head is close to the bottom of post thread and facing front position.
2. Using a 3/4" open face wrench (not supplied), turn the Burner Head attachment locknut counter clockwise. Turn until the locknut is snug against the Burner Head at the attachment point, locking the Burner Head from further movement.

CC +

1. Turn Burner Head onto post thread at the attachment point using a clockwise motion. Turn until burner head is close to the bottom of post thread and facing front position.
2. Place the Heat Shield over the Burner Head so that the notched out portion fits around the threaded post, between the Burner Head attachment point and the Burner Head locknut.
3. Using a 3/4" open face wrench (not supplied), turn the Burner Head attachment locknut counter clockwise. Turn until the locknut is snug against the Burner Head at the attachment point with the Heat Shield pressed between them, locking the Burner Head from further movement.

CC ++

1. Turn Burner Head onto post thread at the attachment point using a clockwise motion. Turn until burner head is close to the bottom of post thread and facing front position.
2. Place the Heat Shield over the Burner Head so that the notched out portion fits between the Burner Head attachment point and the Burner Head locknut.
3. Using a 3/4" open face wrench (not supplied), turn the Burner Head attachment locknut counter clockwise. Turn until the locknut is snug against the Burner Head at the attachment point with the Heat Shield pressed between them, locking the Burner Head from further movement.

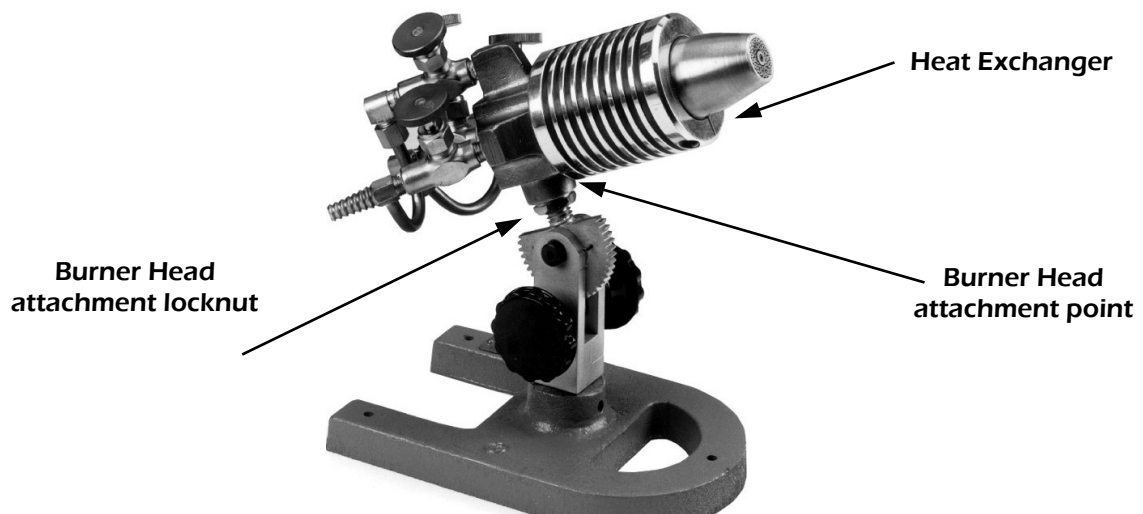

CC Burner shown with Rack and Pinion Mount

Carlisle Machine Works, Inc.,
P.O. Box 746, 412 S. Wade Blvd., Bldg. #5, Millville, NJ 08332
Toll Free Phone : (800) 922 - 1167 Local Phone : (800) 825 - 0627
Fax: (856) 825 - 5510
Website: carlislemachine.com Email: carlisle@carlislemachine.com



Pre-mixed Centerfire:

The centerfire of the CC Burner is pre-mixed. Pre-mixed burners mix the gas and oxygen together before exiting the burner. This produces a very fine flame that works well for small and intricate flameworking. As with all pre-mixed flames, it is possible for combustion to take place inside of the burner if the conditions of the flame permit (this is commonly known as Flashback). The CC Burner has been designed with this in mind, and has been engineered to significantly reduce the chance of a Flashback occurrence. In order to further reduce the chances of Flashback, the burner should not be run lower than the recommended pressures and the centerfire flame length should not be shorter than a 1/2". Although significant Flashback occurrences could damage the burner, this should not be a hazard to the user with the proper safeties installed (see "Safety Recommendations").

The CC, CC Plus, CC ++ and CC RP models all use the same centerfire tips and should experience the same flames under similar conditions. The #5 and #3 centerfire tips are piloted (piloting is a small set of orifices that support the main flame) and as such can be pushed harder without the flame being pushed off of the face of the burner. The CC-H centerfire tip is not piloted since a hydrogen oxygen flame is a quick burning flame that does not require piloting. The use of hydrogen is not recommended with the #5 or #3 centerfire tip as this may cause the tip to burn out very quickly. This condition might be recognized as an orange glow of the metal in the end of the burner.

The centerfire of the CC Burner should not be shutoff during any burner operations. Running the outerfire of the CC Burner without the centerfire can cause heat build-up (see "Heat Build-up and Carbon Build-up") and other undesirable operating conditions.

Surface Mixed Outerfire:

The outerfire of the CC Burner is surface mixed. Surface mixed burners deliver the gas and oxygen to the face separately so that the mixing of gases happens as they exit the burner face. This produces a large yet safe flame for working with larger applications. Surface mixed burners should not have the possibility for combustion to take place inside of the burner (this is commonly known as Flashback) since the gas and oxygen are not mixed until they exit the burner. However, certain conditions (such as an internal leak) could cause a Flashback occurrence with the outerfire. If this is suspected please contact Carlisle for a burner evaluation.

The CC, CC Plus, CC++, and CC RP models have varying size outerfires. The outerfire of the CC Burner has two rows of porting, where as the CC Plus and CC RP have three rows of porting, the CC++ has four rows of porting. The outerfire is constructed of stainless steel tubing. The gas is delivered to the face of the burner through the inside of this tubing. The oxygen is delivered through the open spaces around the tubing.

The outerfire of the CC Burner should not be shutoff for long periods of time during any burner operations. Operating the centerfire of the CC Burner without the outerfire can cause heat build-up (see "Heat Build-up and Carbon Build-up") and other undesirable operating conditions. If it is desired to have the outerfire off, then it is recommended that the gas be turned off and the oxygen be left on slightly. The flow of the oxygen through the outerfire will help to retard heat build-up within the burner. **We do not recommend the centerfire remaining lit with gas only as a pilot for extended time.**

Carlisle Machine Works, Inc.,
P.O. Box 746, 412 S. Wade Blvd., Bldg. #5, Millville, NJ 08332
Toll Free Phone : (800) 922 - 1167 Local Phone : (800) 825 - 0627
Fax: (856) 825 - 5510
Website: carlislemachine.com Email: carlisle@carlislemachine.com



Control Valves:

There may be up to six valves (with Optimizer use), located on the back of the CC Burner. Standard models require four control valves. Two of the controls have red handles and are used for metering the gas flow to the centerfire and outerfire of the burner. Two of the controls have green handles and are used for metering the oxygen flow to the centerfire and outerfire of the burner. The inner most valves control the centerfire and the outer most valves control the outerfire. The other valves control the metering of compressed air into the system.

These control valves are finely threaded and thus require several full turns to become fully open or fully closed. When using these valves to control the flames, it is best to make small incremental adjustments rather than full turns. Quick or large adjustments could cause the flame to become unstable and even blow off of the face of the burner. In time, the user will learn the best way to control the burner for their application.

The valve stems are threaded and secured into the valve body via a nut. This nut is threaded onto the valve body and the stainless steel stem extends through this nut. Depending on how tightly this nut is threaded down compressing the Teflon seals onto the valve body, the stainless steel stem will be harder or easier to turn. If the nut is tightly threaded down onto the valve body, the stem will have more resistance to movement. By loosening this nut, the stem will become easier to adjust. Loosening the nut can also cause a leak to form around the stem from the nut sealing area. Be sure to check for leaks (see *"Checking for Leaks"*) anytime that this nut is adjusted.

When closing the control valve, the valve should be adjusted only until it seats and stops turning. The valve should not be forced or "torqued" down any further. By turning the valve handle with force, beyond its seal positioning, and once has seated, great pressure may be placed on the seat. This will cause the seat or valve stem to become deformed or "scored" and will result in a leak that can not be fixed and will require the replacement of the valve.

Checking for Leaks:

Before operating the CC Burner for the first time and once a month (see *"Maintenance"*) the burner should have the control valves and all connections checked for leaks. Follow the procedure below to check for leaks.

1. Connect air at 25 PSI to the burner.
2. Dip the head of the burner into a bucket of water.
3. Cycle through the control valves turning each one on and then shutting it off. When the control valve is opened there should be a rush of bubbles in the water. After shutting the control valve off, wait about 30 seconds to watch for any new bubbles. If bubbles appear at any rate, this would indicate a leak in the control valve.
4. Remove the head from the water and use the air pressure to blow out any residual water.
5. Mix soap (liquid soap is best for this) and water to form a bubbly mixture (for leak detection).
6. Turn on all four control valves.
7. Apply the soapy mixture to all threaded connections and valve stems. If any of these areas produces bubbles after applying the soapy mixture, the connection may have a leak.
8. Close all control valves and disconnect the air.

If a leak is detected, contact a Carlisle Representative for assistance.

Carlisle Machine Works, Inc.,
P.O. Box 746, 412 S. Wade Blvd., Bldg. #5, Millville, NJ 08332
Toll Free Phone : (800) 922 - 1167 Local Phone : (800) 825 - 0627
Fax: (856) 825 - 5510
Website: carlislemachine.com Email: carlisle@carlislemachine.com



Startup and Shutdown:

To startup the CC Burner, follow the procedure below.

1. First partially open the centerfire gas control valve and ignite the gas with either an open flame or striker. Be sure that your hands, clothing, and other flammable objects are not near the face of the burner while igniting the flame.
2. Then open the centerfire oxygen control valve to produce a blue focused flame.
3. Next slowly open the outerfire gas control valve. The centerfire flame will ignite the gas.
4. Then open the outerfire oxygen control valve to produce a blue focused flame.

To shutdown the CC Burner, follow the procedure below.

1. Reduce flow of all gases to burner
2. First close off the outerfire oxygen control valve.
3. Then close off the outerfire gas control valve.
4. Next close off the centerfire oxygen control valve.
5. Then close off the centerfire gas control valve.

Heat Build-up and Carbon Build-up:

If too low (short candles on the burner) the burner tip may overheat and begin to glow red. If this condition continues, damage to the burner will occur. Some inappropriate working conditions can cause heat build-up in the burner. This heat build-up will cause damage to the burner and also present a danger to the user if a heated area of the burner is touched by the user. Operations that cause excessive heat build up in the burner is not the responsibility of Carlisle and will not be covered under warranty.

The Heat Exchanger is an aluminum finned collar that is affixed over the burner shell. The purpose of the heat exchanger is to remove heat from the burner body and disperse it into the air. This is a standard feature for the CC Burner. If the atmosphere is superheated by either flame backwash (the flame reflecting from a worked piece back onto the burner) or other situations, this may cause the Heat Exchanger to work in the reverse and pull heat into the burner from the atmosphere. If this is the case, we suggest the water cooling option (see *"Options and Accessories"*).

Excessive Heat build-up is the cause for carbon build-up. Carbon build-up is the formation of carbon inside of the burner (natural by-product of fuel gas). This often results in degraded performance of the burner and possibly may cause carbon to expel out of the burner or form at the end of the tubes. Carbon is present in the fuel gas (except hydrogen) and effectively causes the flame to have more heat potential. If the stainless steel in the burner becomes heated to a significant level, the carbon from the fuel gas will bond to the walls of the stainless steel. When this occurs, the burner must be cleaned (see *"Maintenance"*). Propane has a very high carbon content and will almost certainly cause carbon build-up with excessive heat.

Below are some of the things the user can do to help retard heat build-up.

- Flames that have higher oxygen content run cooler. Use this type of flame whenever possible.
- Do not run the burner without the centerfire flame.
- Do not run the burner without the outerfire flame or at least some oxygen flowing through the outerfire for extended periods of time.
- Do not use shorter flames that burn very close to the face of the burner (end of tubes to glow red).
- Do not use lazy flames that are not directed outward from the face of the burner.
- Do not work too close to a piece that would cause flame backwash.

Carlisle Machine Works, Inc.,
P.O. Box 746, 412 S. Wade Blvd., Bldg. #5, Millville, NJ 08332
Toll Free Phone : (800) 922 - 1167 Local Phone : (800) 825 - 0627
Fax: (856) 825 - 5510
Website: carlislemachine.com Email: carlisle@carlislemachine.com



Maintenance:

Before any maintenance is performed, the user should be sure to use appropriate safety measures such as wearing safety goggles.

- If the CC Burner experiences carbon build-up (see *"Heat Build-up and Carbon Build-up"*), then the burner should be cleaned regularly. The tubes can be cleaned using a .026 diameter piano wire. When cleaning the tubes, it is important to be sure that the user is very careful and gingerly pokes at the carbon. It is very possible to have the cleaning tool get stuck inside the burner. Also, a light amount of air flow through the torch will cause the dislodged carbon to come out of the face of the burner rather than falling back into the body.
- The CC Burner should be checked for leaks in the valves and all threaded connections once a month (see *"Checking for Leaks"*)
- It is also recommended that the CC Burner be sent back to Carlisle once a year for an evaluation and/or cleaning. Please contact a Carlisle Representative to schedule your evaluation.
- **Do not disassemble the burner for any reason.**

Frequently Asked Questions:

I just started up my new CC Burner and there are sparks coming out in the flame. Is there something wrong?

- The CC Burner is a precision crafted burner. We clean it out thoroughly before shipping to remove any excess materials and burrs from the inside of the torch. However, there are sometimes particles or burrs of metal that get left in the burner. The sparks are actually these minute pieces of metal burning off in the flame. This should subside after short period of use.

Why do I hear a popping sound when I shut off my CC Burner?

- The popping sound is most likely caused by the slow escapement of gases that are leaving the burner after you have shut it off. This is not dangerous to the user or the burner, but can be quite startling to those who hear it. To avoid this sound when shutting down, turn off the oxygen first and then allow two to three seconds before turning off the gas.

Do you recommend running the burner with acetylene?

- We do not recommend using the CC Burner with any fuel gases other than Natural Gas, Propane, or Hydrogen (with a CC-H burner only).

The CC Burner spit out something onto what I was working on. Why did this happen and how can I prevent it?

- If something spits out of the burner, it is most likely carbon that has built up on the inside of the torch (see *"Heat Build-up and Carbon Build-up"*). If it does not appear to be carbon, it is suggested that you look into dirt or particulate in the lines. Other than carbon, there is nothing inside of the CC Burner that would come out of the burner in that way. Therefore, this is usually found to be a problem upstream of the CC Burner.

Why are some of the candles from the outerfire longer than others?

- There are several situations that can cause the flames of the outerfire to vary from one another in small ways. This should not affect the working properties of the burner and is not considered a defect. If there are large differences between the flames, please contact a Carlisle Representative.

**Carlisle Machine Works, Inc.,
P.O. Box 746, 412 S. Wade Blvd., Bldg. #5, Millville, NJ 08332
Toll Free Phone : (800) 922 - 1167 Local Phone : (800) 825 - 0627
Fax: (856) 825 - 5510
Website: carlislemachine.com Email: carlisle@carlislemachine.com**



Safety Requirements:

Below are the safety requirements for use of the CC Burner. These measures will help to ensure the safety of the user.

- Flashback Arrestors should be used with the CC Burner. These devices stop a Flashback from traveling upstream through the lines.
- Didydium Glasses should be worn when working with the CC Burner.
- Protective gloves or clothing should be worn when working with the CC Burner.
- Long hair should be tied back and loose clothing should not be worn when working with the CC Burner.
- The integrity of the burner casing should never be broken. This will cause an internal leak (until repair) that could be potentially very dangerous.
- This product uses fuel gases and when ignited produces a very hot flame.
- **Carlisle Machine Works, Inc. will not be responsible for careless or inappropriate use.**

Helpful Hint with Setting the Neutral Flame:

To test for a neutral flame Glass Alchemy, Ltd. Recommends heating a stick of 087 Amazon Night to a warm orange glow and allow to cool. If the stick is a light sky blue or has a metallic sheen the flame is reducing and needs to be adjusted. Reduce the propane content. If the stick is sky blue it is very reducing and can only be adjusted by reducing the propane pressure at the regulator, usually by 1/2 the pressure (ex. From 2 to 1 pound). If the rod is metallic, adjustments of the regulator of 1/4 pound increments should result in a neutral flame. Ideally the rod should be the same color coming out of the flame as it was going

	Natural Gas	Propane	Hydrogen
Recommended Pressures	5 PSI Gas 10 PSI Oxygen	5 PSI Gas 25 PSI Oxygen	10 PSI Gas 10 PSI Oxygen
Maximum Cubic Foot per Hour - CC	90 Gas 180 Oxygen	60 Gas 320 Oxygen	270 Gas 180 Oxygen
Maximum Cubic Foot per Hour - CC Plus / RP	180 Gas 360 Oxygen	120 Gas 640 Oxygen	540 Gas 360 Oxygen
Maximum BTU per Hour - CC	95,000	150,000	210,000
Maximum BTU per Hour - CC Plus / RP	190,000	300,000	420,000

Carlisle Machine Works, Inc.,
P.O. Box 746, 412 S. Wade Blvd., Bldg. #5, Millville, NJ 08332
Toll Free Phone : (800) 922 - 1167 Local Phone : (800) 825 - 0627
Fax: (856) 825 - 5510
Website: carlislemachine.com Email: carlisle@carlislemachine.com



Warranty and Legal Notice:

Carlisle Machine Works, Inc. warrants that each item of its own manufacture delivered hereunder shall, at the time of delivery and for a period of 12 months thereafter, be free from defects in materials and workmanship; and if any such item shall prove to be defective in material or workmanship under normal intended usage and maintenance during the warranty period upon examination by Carlisle Machine Works Inc., then Carlisle Machine Works, Inc. shall repair or replace, at its sole option, such defective item (s) at its own expense; provided, however, that the owner shall be required to ship such defective item(s), freight prepaid, to Carlisle Machine Work's Plant in Millville, NJ. Please contact a Carlisle Representative before returning your item(s) to Carlisle Machine Works, Inc.

The warranty on components not manufactured by Carlisle Machine Works, Inc. is limited to the warranty provided by the original manufacturer of said components. All warranties hereunder are expressly limited to repair or replacement of defective items as set forth herein, and in no event shall Carlisle Machine Works, Inc. be liable for special incidental or consequential damages by reason of any breach or warranty of defect in material or workmanship. Carlisle Machine Works, Inc. shall not be responsible for repair or replacement of items which have been altered by others than authorized Carlisle Machine Works, Inc. personnel.

The manufacturer strongly objects to anyone but authorized Carlisle Machine Works, Inc. personnel breaking the integrity of the burner casing. The manufacturer will declare all warranties null and void and user will be liable for all injuries or damages occurring as a result of the user attempting or succeeding to disassemble, repair, or replace internal parts of the burner or otherwise operate the burner improperly.

Limitation of Liability:

It is expressly agreed that the liability of Carlisle is Machine Works, Inc. is limited and therefore does not function as an insurer. The purchaser and/or user agree that Carlisle Machine Works, Inc. is not liable for loss, harm, or damage due directly or indirectly to any occurrences of use or consequence therefrom. If Carlisle Machine Works, Inc. should be found liable to anyone in any theory (except any express warranty where the remedy is set forth in this document) for loss, harm, or damage, the liability of Carlisle Machine Works, Inc. shall be limited to the lesser of the actual loss, harm, or damage, or the original purchase price of the involved equipment, system, service when sold, or service when performed by Carlisle Machine Works, Inc. to its customers. This liability is exclusive and regardless of cause or origin resulting directly or indirectly to person or property from:

- A. The performance or non-performance of any obligation set forth in this warranty and warranty policy.
- B. Any agreement, oral or written, including specifications, between Carlisle Machine Works, Inc and the customer.
- C. Negligence, active, passive or otherwise, of Carlisle Machine Works, Inc. or any of its agents, employees, or independent contractors.
- D. Breach of any judicially imposed warranty or covenant and misrepresentation or strict liability involvement.

Please visit the our website at www.carlislemachine.com for more details about the warranty and product information.

**Carlisle Machine Works, Inc.,
P.O. Box 746, 412 S. Wade Blvd., Bldg. #5, Millville, NJ 08332
Toll Free Phone : (800) 922 - 1167 Local Phone : (800) 825 - 0627
Fax: (856) 825 - 5510
Website: carlislemachine.com Email: carlisle@carlislemachine.com**

